

4 March 1986

to: C. Read 9Z21 Carling  
from: P. Cashin 9X00 Carling  
copies to: K. Buechner 0B00 Carling  
P. Trussler 9Z01 Carling

subject: United States Patent No. 1,199,137  
Issued on 7 January 1986  
Title: TELEPHONE SET WITH TWO POSITION MOUNTING  
WITH ALTERNATE SEATING OF HANDSET  
Inventor: C. D. Read

I was pleased to hear that a patent on an invention by yourself,  
entitled:

TELEPHONE SET WITH TWO POSITION MOUNTING WITH  
ALTERNATE SEATING OF HANDSET

has been granted in the United States.

Enclosed is your copy of the patent. Congratulations.

*Peter*

Peter M. Cashin  
Assistant Vice-President  
Computing Technology and Design Interpretive



Consumer and  
Corporate Affairs Canada

Consommation  
et Corporations Canada

(11) (A) No. **1 199 137**

(45) ISSUED 860107

(52) CLASS 379-104

(51) INT. CL. H04M 1/11<sup>4</sup>

(19) (CA) **CANADIAN PATENT** (12)

(54) Telephone Set with Two Position Mounting with  
Alternate Seating of Handset

(72) Read, Clifford D.,  
Canada

(73) Granted to Northern Telecom Limited  
Canada

(21) APPLICATION No. 441,787

(22) FILED 831123

No. OF CLAIMS 6

**Canada**

1199137

This invention relates to a telephone set which can be mounted in either of two positions, for example on a vertical or a horizontal surface, the handset seating on the telephone set base in one of two alternate positions depending upon the mounting position of the base.

Many desk mounting, or other horizontal surface mounting, telephone sets have the handset resting on the base in a cross-wise position, usually at the rear of the base. Wall mounting telephone sets, or other vertical surface mounting, often have the handset resting in a vertical position, hanging down with one end, usually the transmitter end, resting on the hook switch actuator.

To provide a telephone set which can be mounted, as desired, on a vertical surface or a horizontal surface, it is usual to have the handset seating in the same position as is often used in wall mounting, that is extending from top to bottom, or back to front, depending on mounting position.

The present invention provides a telephone set which can be positioned on a vertical surface or a horizontal surface. The telephone set base is configured at the end which is the top in a vertical position and the rear in a horizontal position to provide two alternate seating positions for the handset. In accordance with the invention, the telephone set base has an upwardly and outwardly projecting member with two surfaces substantially at right angles, defining a corner, and a hook switch actuator positioned at the corner. The two surfaces face upwards and outwards in a vertical mounting and forwards and upwards in a horizontal mounting. Also in accordance with the invention, the handset has a recess in the



1199137

underside of the central portion, the recess seating on that surface of the projecting member which is facing upwards, and moving the hook switch actuator.

The invention will be readily understood by the following description of two embodiments, by way of example, in conjunction with the accompanying drawings, in which:-

Figure 1 is a perspective view of one form of telephone set base, in a vertical mounting position;

Figure 2 is a side view of the base illustrated in  
10 Figure 1;

Figure 3 is a perspective view of another form of telephone set base, also in a vertical mounting position;

Figure 4 is a perspective view of a form of handset for use with the bases of Figures 1 and 2 and Figure 3;

Figure 5 is a side view of the base of Figure 4 illustrating the handset seated, in a vertical mounting; and

Figure 6 is a side view of the base of Figure 4 illustrating the handset seated, in a horizontal mounting.

In the example illustrated in Figures 1 and 2, a  
20 telephone set base indicated generally at 10 is of rectangular form and relatively thin having front and back surfaces 11 and 12 respectively. On the front surface 11 is a dial or key pad, indicated generally at 13. The base extends upwards, as seen in Figures 1 and 2, having a portion 14 of reduced width. A forwardly and upwardly projecting member or portion 15 extends from the top edge 22 of portion 14. The projecting member has two surfaces 16 and 17 which are at right angles, defining a corner 18. Projecting

1199137

through the corner 18 is a hook switch actuating member 19. The hook switch actuating member, in the example moves at an angle to both surfaces 16 and 17, for example at approximately 45° to the horizontal, as indicated by arrow 20. In Figure 2 the base is seen mounted against a wall or similar vertical surface 21.

Figure 3 illustrates an alternative base 25, again of generally rectangular form and relatively thin. A dial or key pad 26 is provided at the front surface 27. A forwardly and upwardly projecting member or portion 28 extends at the top edge of the base, having two surfaces 29 and 30 at right angles and defining a corner 31. Projecting through the corner 31 is a hook switch actuating member 32. As in the arrangement illustrated in Figures 1 and 2, the actuating member 32 moves at an angle to the surfaces 29 and 30, for example at approximately 45° as indicated by arrow 33. The base 25, in Figure 3, is illustrated as mounted against a wall or similar vertical surface 34.

Figure 4 illustrates a handset 35 which can be used with the telephone set bases illustrated in Figures 1 and 2 in Figure 3. As seen, the handset has a central portion 36, held by the hand of the user when the telephone is in use. At each end are projections 37 and 38 in which are positioned the transmitter and receiver respectively. The handset has a recess 39 in the undersurface of the central portion 36. In Figure 4 the undersurface, indicated at 40, is facing upwards, but in position on the base faces downward.

The recess 39 is shaped to seat on the forwardly and upwardly projection member of the base, member 15 in Figures 1 and 2 and member 38 in Figure 3. When the telephone set base is mounted on

1199137

a vertical surface, the recess 39 seats on the upward facing one of the two surfaces of the projecting member, that is on surface 16 in the example of Figures 1 and 2 and on surface 29 in the example of Figure 3. When the telephone set base is mounted on a horizontal surface, the recess 39 seats on the surfaces 17 or 30 as these will now be upward facing.

This is seen in Figures 5 and 6 where the example of a telephone set base as illustrated in Figure 3, is shown in both vertical and horizontal mounting, with the handset on the base. In Figure 5, the vertical mounting mode, the handset is seen seated on the surface 29, while in Figure 6, the horizontal mounting mode, the handset is seen seated on surface 30. In both examples, the hook switch actuating member 32 has been pushed in, to actuate the hook switch to an on-hook condition. The actuating member 32 is illustrated diagrammatically, it being inside the projecting member 28.

A similar arrangement will occur with the telephone set base illustrated in Figures 1 and 2. The surfaces 29 and 30 in Figures 5 and 6 correspond to the surfaces 16 and 27, in Figures 1 and 2 and corresponding seating of the recess in the handset will occur.

Other forms and shapes, of telephone set bases and handsets, can be used to give the same facility. It will be appreciated that, with the actuating member 32 and 19, acting at 45° to the surfaces 29 and 30 and surfaces 16 and 17, the pressure on the actuating member is the same, whether the base is mounted on a vertical or horizontal surface.

1199137

THE EMBODIMENTS OF THE INVENTION IN WHICH AN EXCLUSIVE  
PROPERTY OR PRIVILEGE IS CLAIMED ARE DEFINED AS FOLLOWS:

1. A telephone set comprising a base and a handset, said base comprising a rectangular main body portion having back and front parallel surfaces, and a projecting portion extending from a top edge of said main body portion forwardly and upwardly, said projecting portion including two surfaces extending substantially at right angles to define a corner, one surface extending parallel to said front surface and the other surface extending parallel to said top edge, and a hook switch actuating member extending through said corner; said handset including a central portion extending between transmitter and receiver housings, and a recess in an undersurface of said central portion, said recess dimensioned to sit over said projecting portion of said base, the arrangement such that said handset rests on one of said surfaces of said projecting portion when said base is on a substantially horizontal surface, and rests on the other of said surfaces of said projecting portion when said base is positioned on a vertical surface.

2. A telephone set as claimed in claim 1, said base including a second back portion extending up from said main body portion, and of a reduced width relative to said main body portion, said projecting portion extending from a top edge of said second body portion.

3. A telephone set as claimed in claim 2, said projecting portion having a rectangular cross-section from a side of said base.

5

1199137

4. A telephone set as claimed in claim 1, said projecting portion including two parallel surfaces extending forwardly and upwardly, one of said parallel surfaces extending from the back surface of said base and the other of said parallel surfaces extending from the front surface of said base, to connect to said two surfaces extending substantially at right angles.
5. A telephone set as claimed in claim 1, said hook switch actuating member supported for movement at approximately 45° to the horizontal.
6. A telephone set as claimed in claim 1, including a push-button dial on said front surface of said base.

6



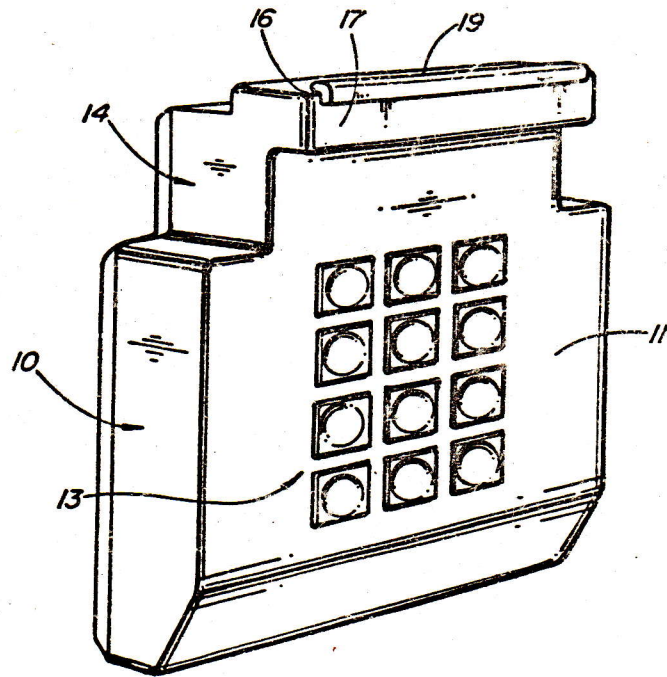

FIG. 1

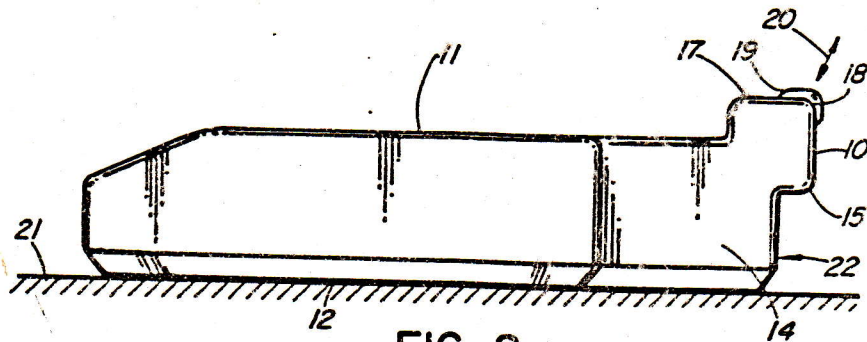

FIG. 2

S

1199137  
3-2

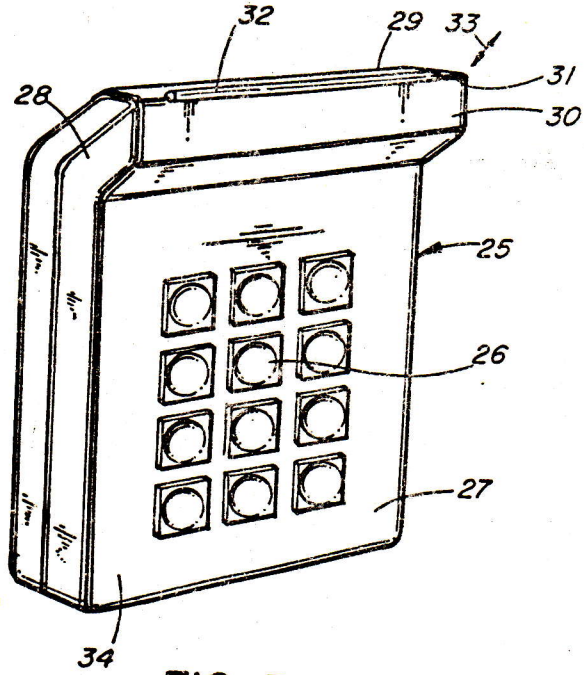

FIG. 3

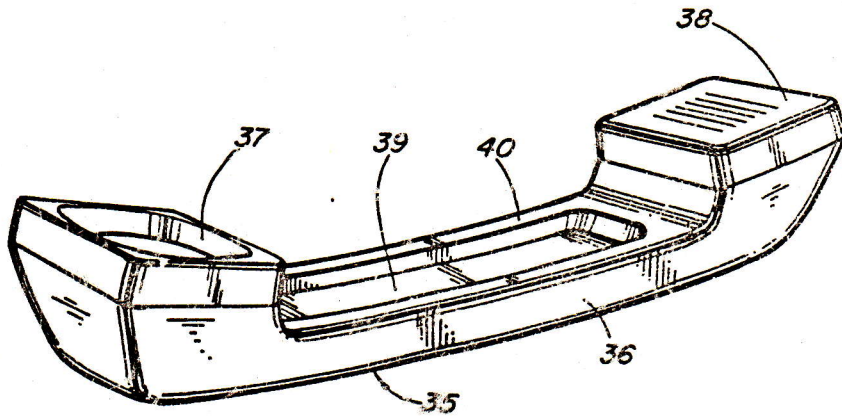

FIG. 4

S

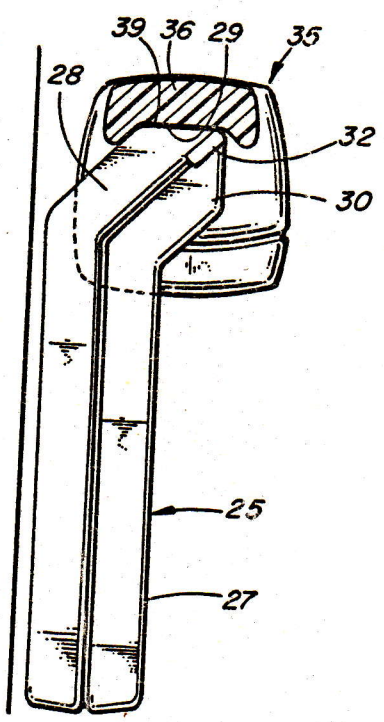

FIG. 5

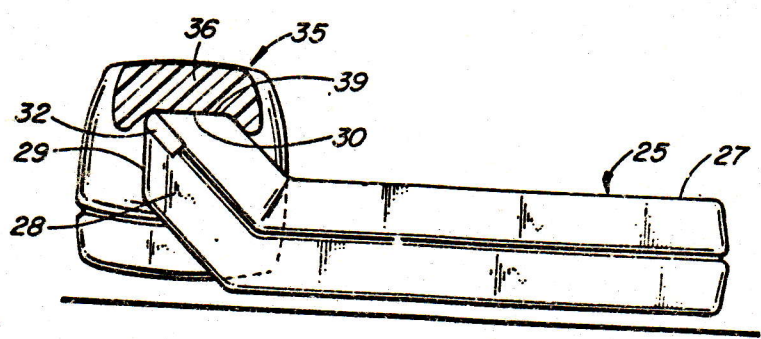

FIG. 6

*J*